

# ProgressivTube®

## PASSIVE SOLAR WATER HEATERS



The ProgressivTube® passive solar water heater is a self-contained unit that acts as a solar collector and storage tank integrated into one piece of equipment. In most systems the unit is utilized as a pre-heater to a terminal, instantaneous or conventional water heater.

The ProgressivTube® is a passive system because it has no moving parts and operates on local water pressure and solar radiation. There are no pumps or controls to maintain and no electrical energy is required to make it function. Once installed the system will operate automatically. When hot water is used in the household, solar preheated water is drawn into the conventional

water heater, reducing or eliminating electricity or gas usage for heating water. However, as with all solar water heaters, the total amount of solar contribution to the system is dependent upon the hot water consumption pattern of the household, daily weather conditions, and variable amounts of available sunlight throughout the year.



The all copper collector/storage tank of a ProgressivTube® unit absorbs solar radiation through its selective surface coating which raises the temperature of the water stored in the collector. It is well insulated with closed cell foam and the unit is double glazed for increased heat retention. The 4" diameter copper tubes are welded into a series flow pattern so that the top of the lower tube feeds the

bottom of the next tube. This allows the ProgressivTube® unit to contain the colder replacement water in the lower tubes where it is heated by the sun as it flows from one tube to the next. Each time hot water is used, the ProgressivTube's® innovative design eliminates the cooling down of the remaining heated water that normally occurs in other types of solar water heating systems. Not only does this design ensure the delivery of the hottest water, but it also provides more hot water at a higher temperature and with a faster recovery time than solar systems of similar capacity.

## HOW IT WORKS

101 Copeland St.  
Jacksonville, FL  
32204 U.S.A.

Telephone:  
(904)358-3720

FAX Line:  
(904)358-3728



## PROGRESSIVTUBE<sup>®</sup> SPECIFICATIONS

**GLAZING GASKETS:** A continuous gasket made of special long life EPDM synthetic rubber is compressed by the glazing caps to seal out the weather. The inner glazing spline is made of high-temperature tolerant EPDM.

**GLAZING:** Outer glazing is tempered low-iron solar glass with 91% transmittance. Inner glazing is Teflon<sup>®</sup> film, known for its high temperature tolerance (525°F) and its long term durability and stability, transmittance 96%. The 3/4" air space between glazings reduces heat loss.

**FLUID CONNECTIONS:** Inlet and outlet connections are made of nominal 3/4" diameter Type "L" hard copper pipes. This allows for fast, leak free sweat fitting plumbing connections.

**CASE:** The baked-on bronze acrylic finish of the hard temper, T6, extruded aluminum framewall and glazing caps, alloy 6061, assures years of attractive rust-free appearance. All rivets and bolts are aluminum or stainless steel. Aluminum back sheet .025".

**INSULATION:** Rigid closed cell polyisocyanurate foam board, the most efficient insulation available, is used to maximize heat retention. Sides and ends of the unit have 1.5" board, R-value 10; bottom has 2" board, R-value 14; between tank tubes has 1.5" board, R-value 10.

**ABSORBER/STORAGE TANK:** Constructed entirely of copper, the 4" diameter tubes are welded to the interconnecting pipes to form a series flow pattern. The tank is pressured rated to 300psi and is coated with a high-temperature "selective" solar radiation absorption surface that maximizes heat gain and reduces heat loss.

## PROGRESSIVTUBE<sup>®</sup> System Performance Ratings

The PROGRESSIVTUBE<sup>®</sup> and its mounting systems have successfully passed static wind load testing to 180 m.p.h. All PROGRESSIVTUBE<sup>®</sup> models and/or systems meet the following standards:



Florida Solar Energy Center  
(FSEC - GP - 5 - 80)  
(FSEC - GP - 6 - 80)  
(FSEC - GP - 7 - 80)



ASHRAE 95-87  
Thermal Performance  
Standard for Solar  
Water Heaters



Solar Ratings & Certification  
Corp. SRCC Standard 200-88  
(RA 92)  
SRCC OG - 300



Uniform Solar Energy Code  
International Association of  
Plumbing & Mechanical  
Officials

MODEL	FSEC Qnet		SRCC Solar Energy Factor
	(BTU/day)	(KWH)	
PT-20-CN	11,600	3.40	
PT-30-CN	22,100	6.48	1.4
PT-40-CN	28,400	8.33	1.6
PT-50-CN	28,700	8.42	1.6

# PROGRESSIVTUBE<sup>®</sup> SPECIFICATIONS

	PT-20-CN	PT-30-CN	PT-40-CN	PT-50-CN
Volumetric Capacity	67.2 L / 17.9 gal	116.7 / 30.84 gal	156.7 L / 41.4 gal	186.2 L / 49.2 gal
Gross Area	1.17 m <sup>2</sup> / 12.56 ft <sup>2</sup>	2.23 m <sup>2</sup> / 23.98 ft <sup>2</sup>	2.98 m <sup>2</sup> / 32.10 ft <sup>2</sup>	2.98 m <sup>2</sup> / 32.10 ft <sup>2</sup>
Frontal Area	1.0 m <sup>2</sup> / 10.77 ft <sup>2</sup>	2.04 m <sup>2</sup> / 21.91 ft <sup>2</sup>	2.77 m <sup>2</sup> / 29.84ft <sup>2</sup>	2.77 m <sup>2</sup> / 29.84 ft <sup>2</sup>
Dry Weight	41.7 kg / 92.0 lbs	76.2 kg / 174 lbs	99.7 kg / 220 lbs	120.0 kg / 265 lbs
Wet Weight	106.7 kg / 235.2 lbs	192.7 kg / 425 lbs	255.4 kg / 563 lbs	301.0 kg / 664 lbs
Flow Pattern	Series	Series	Series	Series
Test Pressure	1103 KPa / 160 psi	2068 KPa / 300 psi	2068 KPa / 300 psi	2068 KPa / 300 psi
Design Pressure	1034 KPa / 150 psi	1034 KPa / 150 psi	1034 KPa / 150 psi	1034 KPa / 150 psi
Max Design Temp	176°C / 350°F	176°C / 350°F	176°C / 350°F	176 C / 350 F
Operating Temp	4-93°C / 40-200°F	4-93°C / 40-200°F	4-93°C / 40-200°F	4-93 C / 40-200 F

## DIMENSIONS - Metric / Inches

<b>A</b>	211.9 cm / 83.44"	247.5 cm / 97.44"	247.5 cm / 97.44"	247.5 cm / 97.44"
<b>B</b>	55.8 cm / 22"	90.0 cm / 35.44"	120.5 cm / 47.44"	120.5 cm / 47.44"
<b>C</b>	210.5 cm / 82.88"	241.9 cm / 95.25"	241.9 cm / 95.25"	241.9 cm / 95.25"
<b>D</b>	54.3 cm / 21.38"	84.1 cm / 33.125"	114.6 cm / 45.13"	114.6 cm / 45.13"
<b>E</b>	215.6 cm / 84.88"	250.0 cm / 98.44"	250.0 cm / 98.44"	250.0 cm / 98.44"
<b>F</b>	19.7 cm / 7.75"	19.7 cm / 7.75"	19.7 cm / 7.75"	19.7 cm / 7.75"
<b>G</b>	212.1 cm / 83.50"	247.2 cm / 97.31"	247.2 cm / 97.31"	247.2 cm / 97.31"
<b>H</b>	6.0 cm / 2.38"	6.9 cm / 2.75"	6.9 cm / 2.75"	6.9 cm / 2.75"
<b>I</b>	4.1 cm / 1.63"	2.5 cm / 1.0"	2.5 cm / 1.0"	2.5 cm / 1.0"
<b>J</b>	7.6 cm / 3"	8.9 cm / 3.5"	8.9 cm / 3.5"	8.9 cm / 3.5"
<b>K</b>	7.0 cm / 2.75"	7.6 cm / 3.0"	7.6 cm / 3.0"	7.6 cm / 3.0"
<b>L</b>	12.7 cm / 5"	13.9 cm / 5.5"	13.9 cm / 5.5"	13.9 cm / 5.5"
<b>M</b>	37.1 cm / 14.63"	70.5 cm / 27.75"	100.9 cm / 39.75"	100.9 cm / 39.75"
<b>N</b>	56.2 cm / 22.13"	89.7 cm / 35.3"	120.2 cm / 47.31"	120.2 cm / 47.31"
<b>P</b>	8.3 cm / 3.25"	9.2 cm / 3.63"	9.2 cm / 3.63"	9.2 cm / 3.63"
<b>Q</b>	13.0 cm / 5.13"	15.6 cm / 6.13"	15.6 cm / 6.13"	15.6 cm / 6.13"
<b>R</b>	6.0 cm / 2.38"	6.2 cm / 2.44"	6.2 cm / 2.44"	6.2 cm / 2.44"

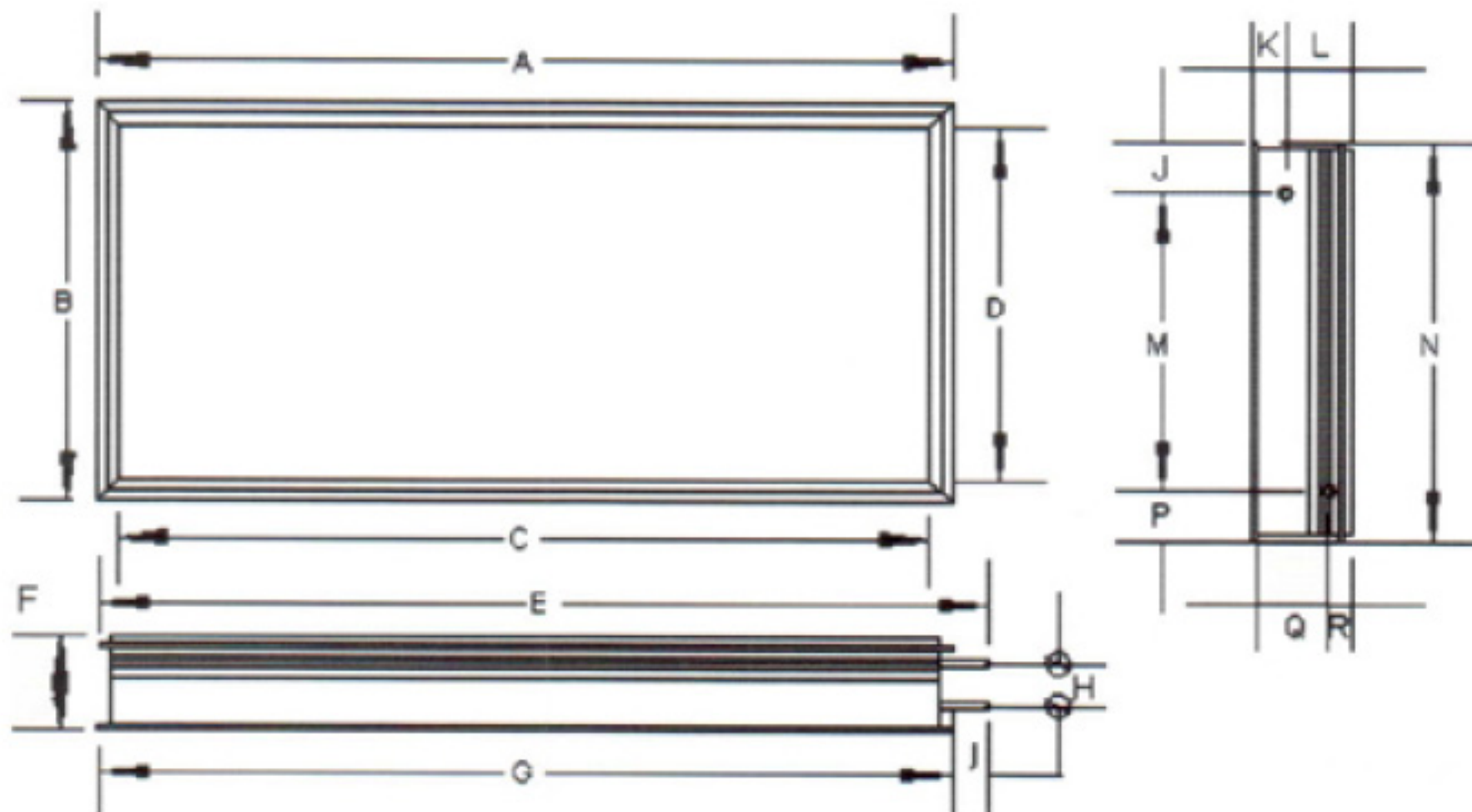

# PROGRESSIVTUBE® Plumbing Valve Kit Components







## 2-WAY SYSTEM



AQUAMIX® - ANTI SCALD TEMPERING VALVE (3/4")

### PARTS:

- 3 - 3/4" CAST BRONZE "T" FITTINGS
- 2 - 3/4" BRONZE BOILER DRAINS
- 1 - 3/4" FULL PORT 3-WAY BALL VALVE
- 1-150 PSI PRESSURE RELIEF VALVE
- 1 - 3/4" FULL PORT 2-WAY BALL VALVE
- 1 - AQUAMIX® - ANTI SCALD TEMPERING VALVE
- 1 - OWNERS MANUAL

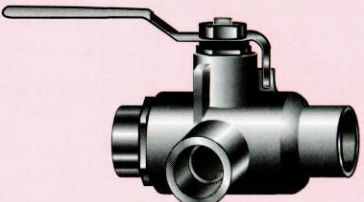
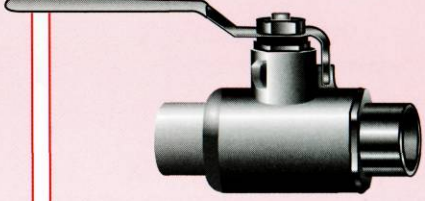
<p>CAST BRONZE "T" FITTING (3/4")</p>  <p>PRESSURE RELIEF VALVE (150 PSI)</p> 	<p>CAST BRONZE "T" FITTINGS (3/4")</p>  	<p>BRONZE BOILER DRAINS (3/4")</p>  	<p>FULL PORT 3-WAY BALL VALVE (3/4")</p>  <p>FULL PORT 2-WAY BALL VALVE (3/4")</p> 
---	--	--	---



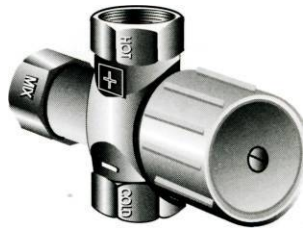



## 3-WAY SYSTEM



AQUAMIX® - ANTI SCALD TEMPERING VALVE (3/4")

### PARTS:

- 3 - 3/4" CAST BRONZE "T" FITTINGS
- 2 - 3/4" BRONZE BOILER DRAINS
- 2 - 3/4" FULL PORT 3-WAY BALL VALVES
- 1-150 PSI PRESSURE RELIEF VALVE
- 1 - 3/4" FULL PORT 2-WAY BALL VALVE
- 1 - AQUAMIX® - ANTI SCALD TEMPERING VALVE
- 1 - OWNERS MANUAL

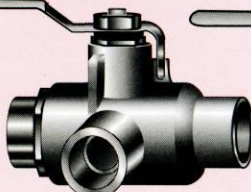
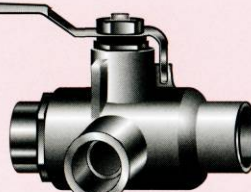
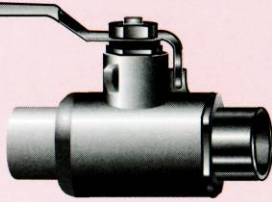
<p>CAST BRONZE "T" FITTING (3/4")</p>  <p>PRESSURE RELIEF VALVE (150 PSI)</p> 	<p>CAST BRONZE "T" FITTINGS (3/4")</p>   <p>BRONZE BOILER DRAINS (3/4")</p>  	<p>FULL PORT 3-WAY BALL VALVES (3/4")</p>  	<p>FULL PORT 2-WAY BALL VALVE (3/4")</p> 
---	---	---	--

# PROGRESSIVTUBE® PLUMBING DIAGRAMS

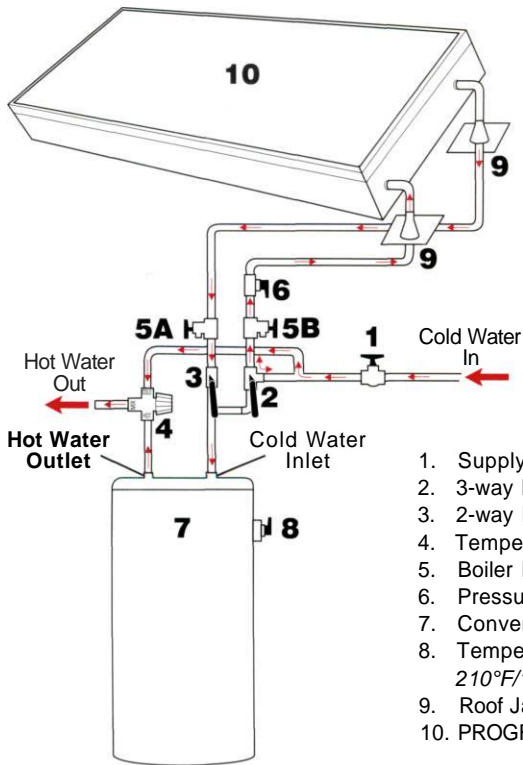

**2-WAY SYSTEM  
FOR ELECTRIC WATER HEATERS**

1. Supply shut off valve
2. 3-way Ball Valve: *Bronze*
3. 2-way Ball Valve: *Bronze*
4. Tempering Valve
5. Boiler Drains: *Bronze*
6. Pressure Relief Valve: *150 psi*
7. Conventional Water Heater
8. Temperature/Pressure Relief Valve:  
*210°F/150psi*
9. Roof Jacks
10. PROGRESSIVTUBE®

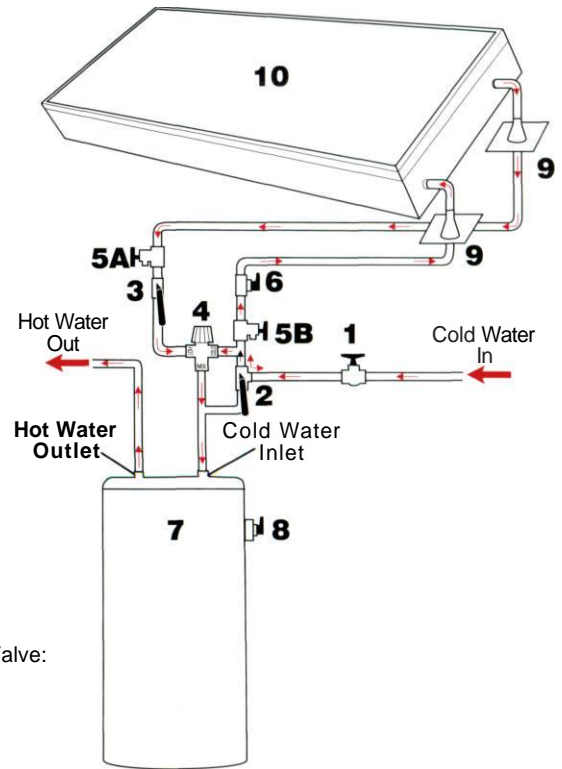

**2-WAY SYSTEM  
FOR GAS WATER HEATERS**

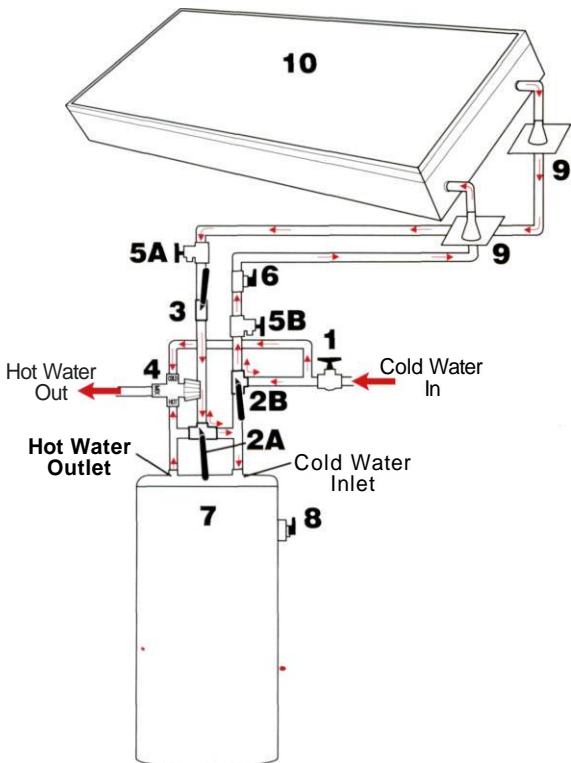

**SRCC OG 300  
3-WAY SYSTEM**

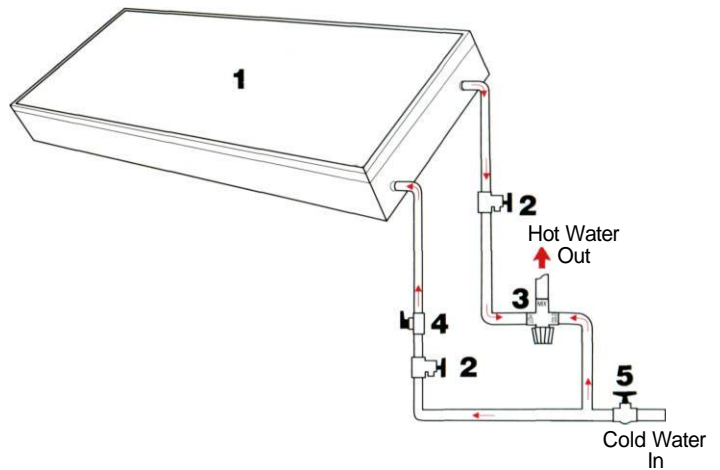

**DIRECT  
SOLAR SYSTEM**

1. PROGRESSIVTUBE®
2. Boiler Drains: *Bronze*
3. Tempering Valve: *Set between 140°F and 160°F*
4. Pressure Relief Valve: *150 psi*
5. Supply shut off valve.

# PROGRESSIVTUBE® MOUNTING SYSTEM

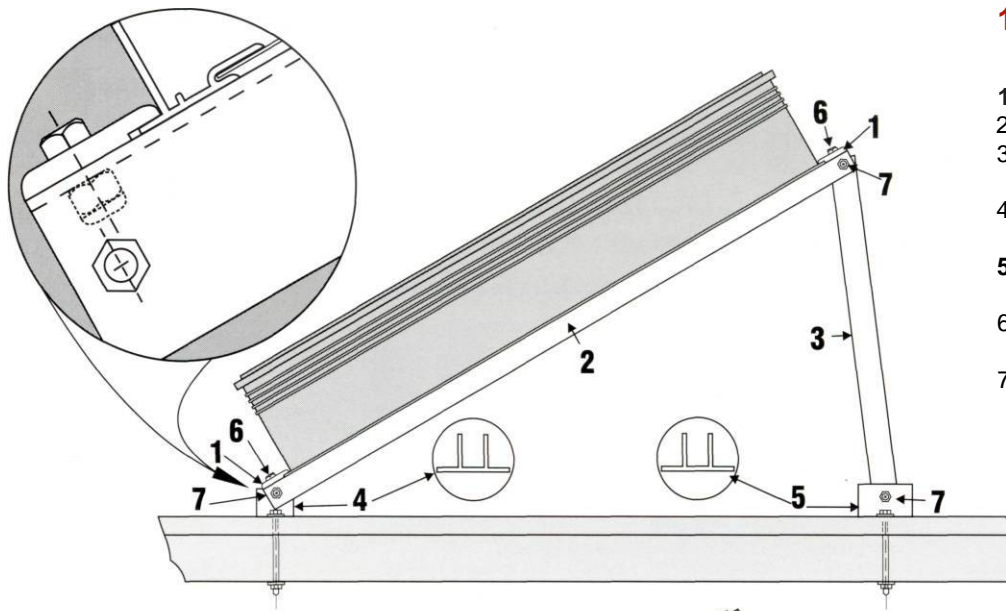

## 1. Adjustable Tilt

### Mounting Hardware Parts:

1. Surface Clamps (4)
2. Cross Channel (2)
3. Standoff, 1-1/4" square tube, 1/8" wall (2)
4. Front Mount Base, 1" Double T (2)
5. Rear Mount Base, 1-1/4" Double T (2)
6. 1"x3/8" Stainless Steel Bolts and Locknuts (4)
7. 2-1/4" x 3/8" Stainless Steel Bolts and Locknuts (6)

## MOUNTING HARDWARE SYSTEMS

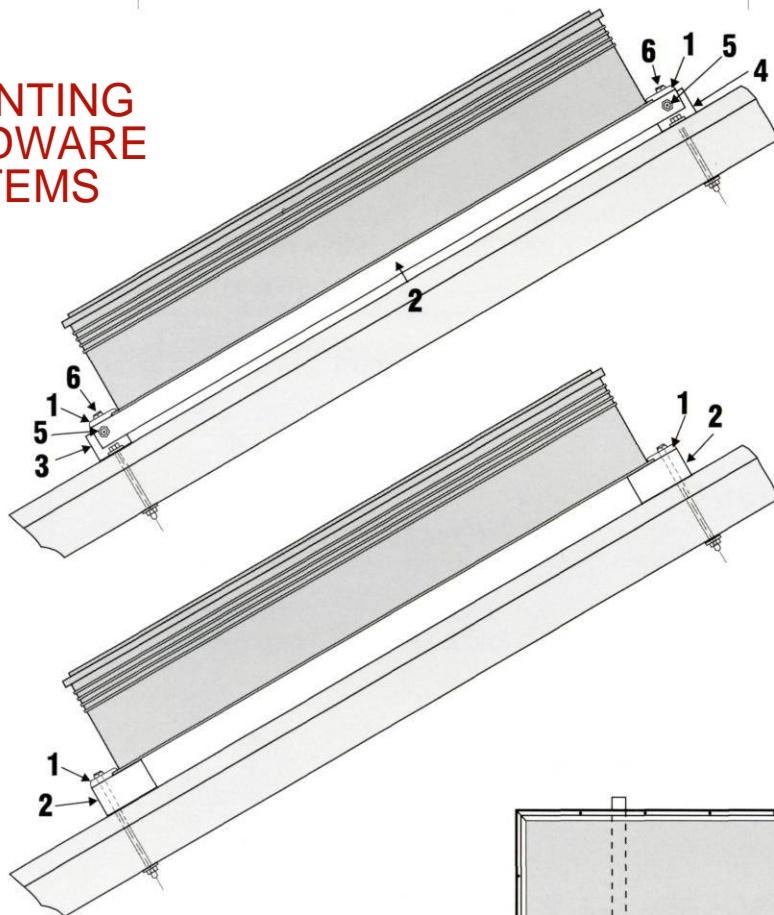

## 2. Fixed Mount

### Mounting Hardware Parts:

1. Surface Clamps (4)
2. Cross Channel (2)
3. Front Mount Base, 1" Double T (2)
4. Rear Mount Base, 1" Double T (2)
5. 2-1/4" x 3/8" Stainless Steel Bolts and Locknuts (4)
6. 1" x 3/8" Stainless Steel Bolts and Locknuts (4)

## 3. Flush Mount

### Mounting Hardware Parts:

1. Surface Clamps (4)
2. Treated 2" x 6" wood blocks under surface clamps supplied by contractor

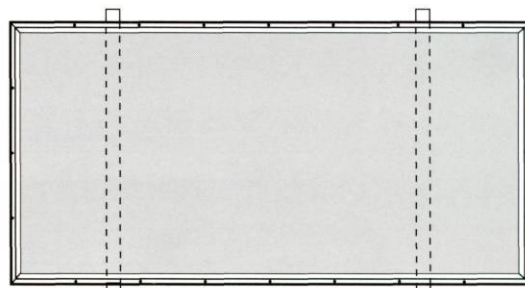

MIN. 42" BETWEEN CROSS CHANNELS