

11.3.06

PROFESSIONAL SEAL
 NORTH CAROLINA
 ENGINEER
 BOBBY L. JOYNER
 8421

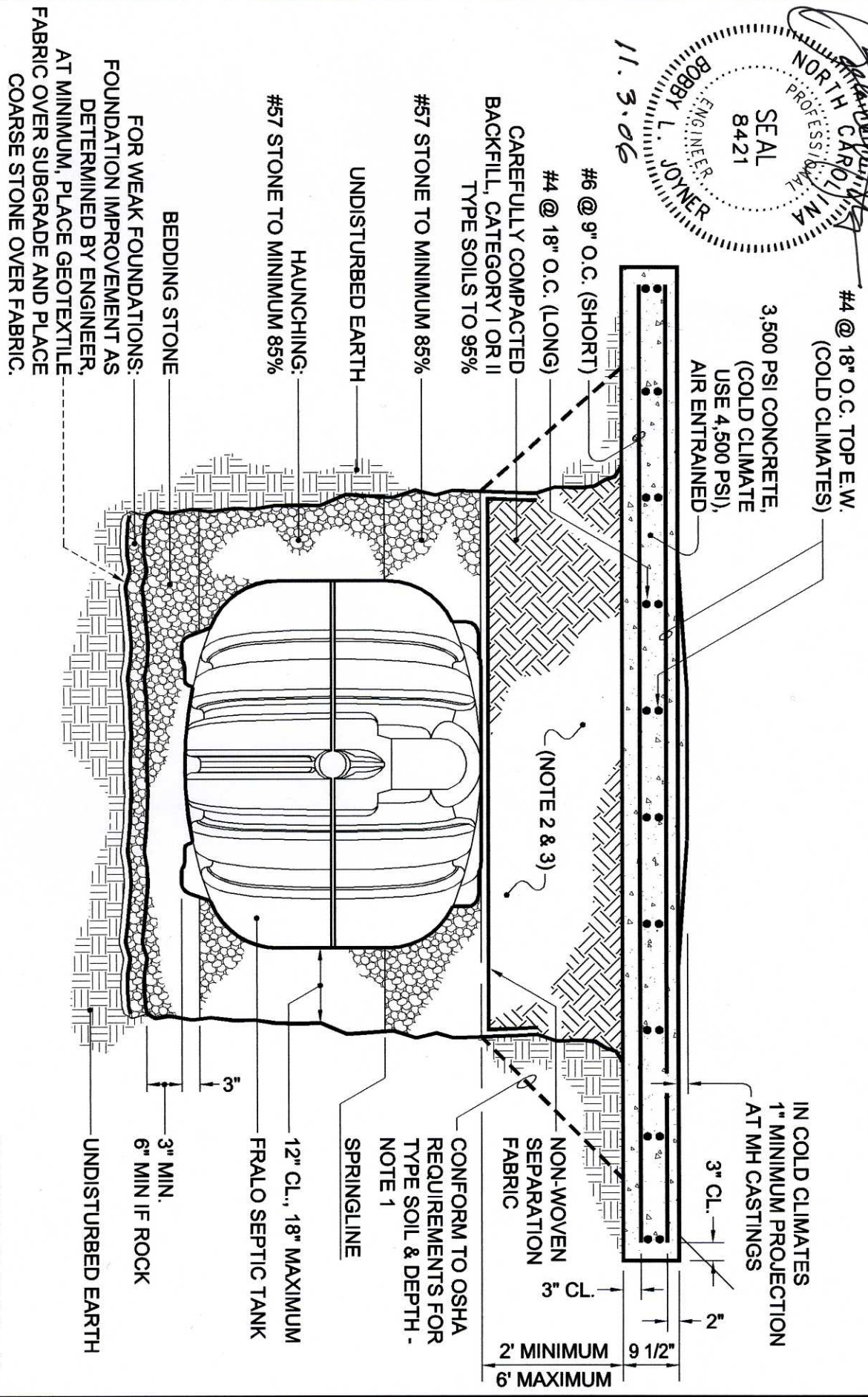

SECTION A

DWG SCALE: NTS
 PLOT SCALE: 1:2
 SHEET #:
 1 OF 3

SEPTTECH™ TANK
H2O LOADING APPLICATION
 THE NEXT GENERATION OF ONSITE WASTEWATER PRODUCTS

FRALO PlastTech

FRALO PLASTECH
 One General Motors Drive
 Syracuse N.Y. 13206
 Call Toll Free 866.943.7256
 www.fralo.net

[Signature]
 11.3.06
 NORTH CAROLINA PROFESSIONAL ENGINEER
 SEAL
 8421
 BOBBY L. JOYNER
 ENGINEER

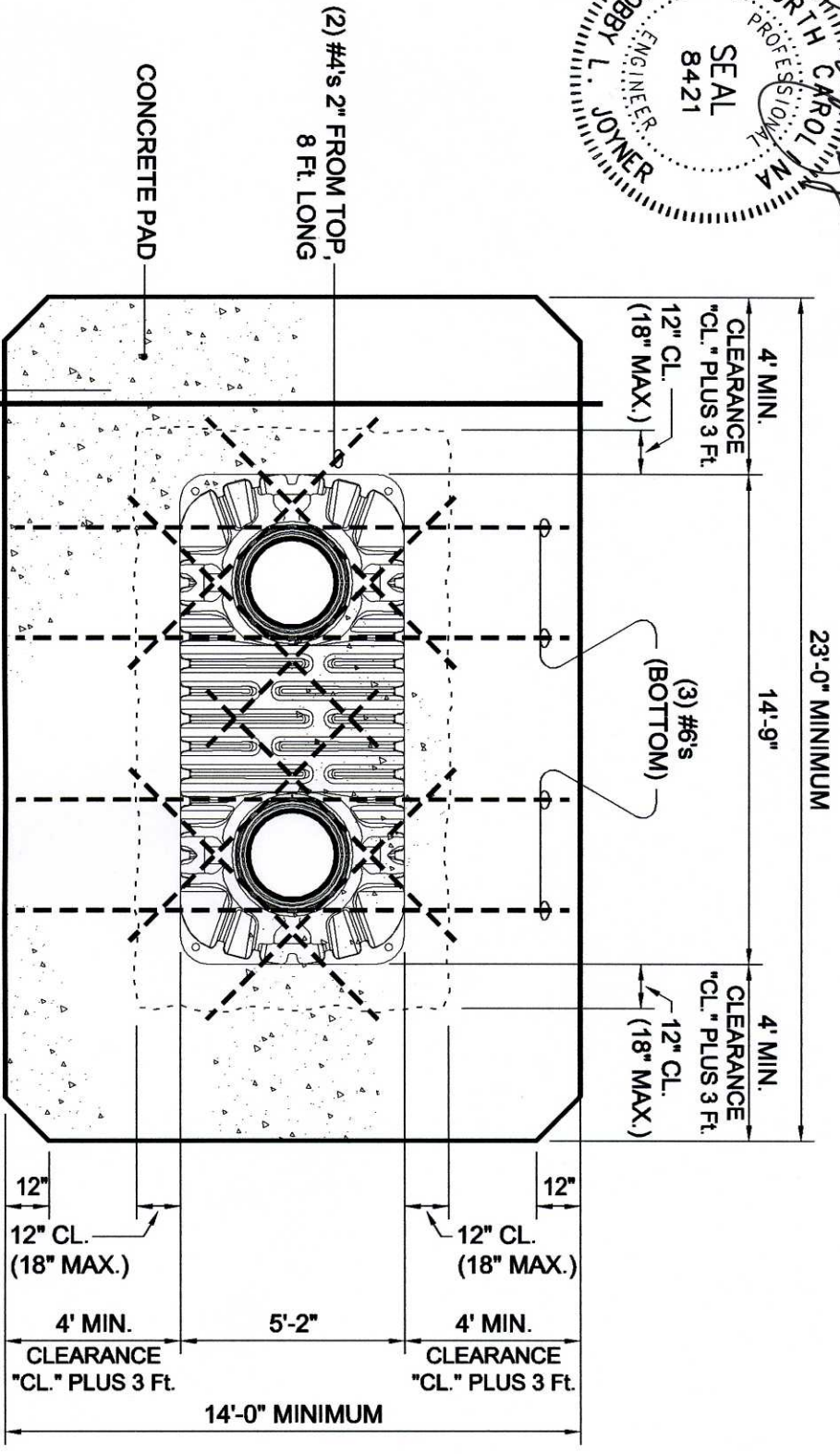

PLAN VIEW

DWG SCALE: NTS
 PLOT SCALE: 1:2
 SHEET #: 2 OF 3

SEPTTECH™ TANK
H2O LOADING APPLICATION
 THE NEXT GENERATION OF ONSITE WASTEWATER PRODUCTS



FRALO PLASTECH
 One General Motors Drive
 Syracuse N.Y. 13206
 Call Toll Free 866.943.7256
 www.fralo.net

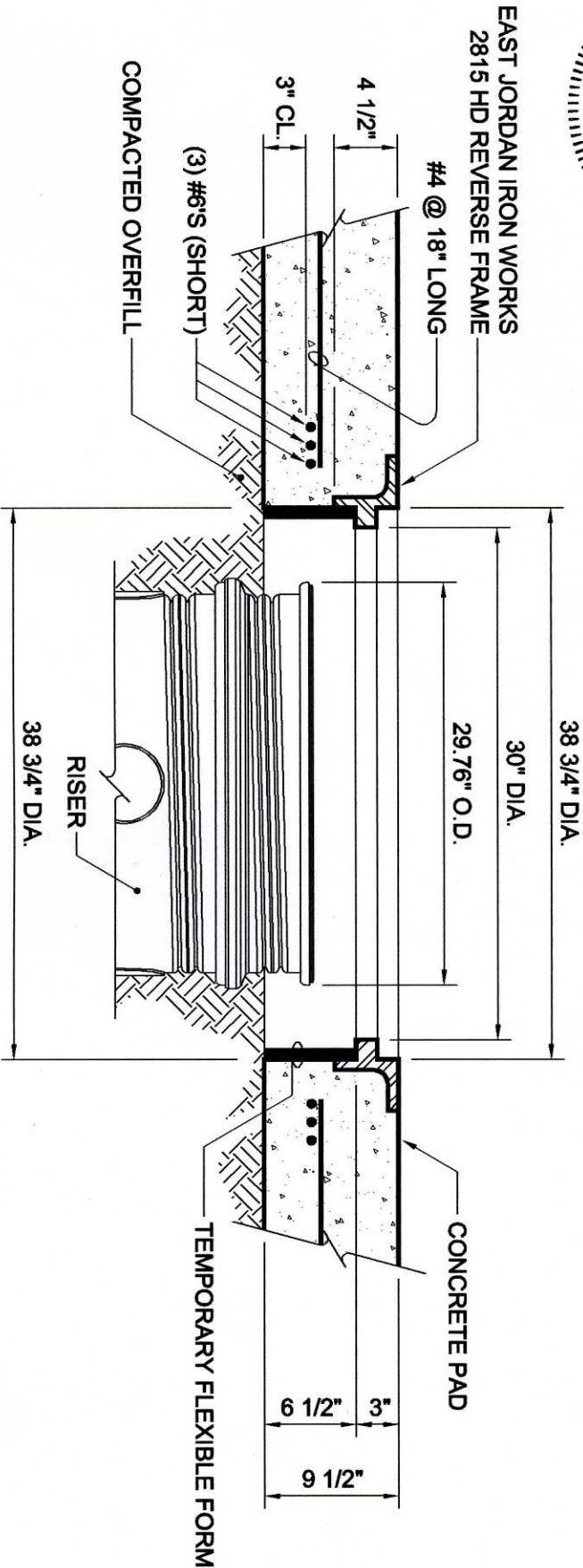
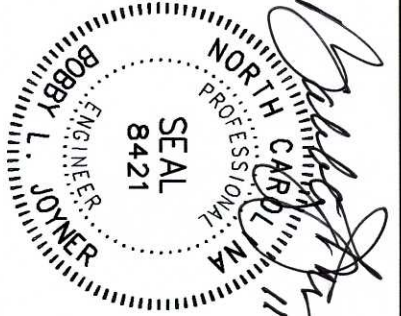

SOIL	REPRESENTATIVE SOIL TYPES		PERCENT COMPACTION STANDARD PROCTOR
	USCS	AASHTO	
GRAVELLY SAND CATEGORY I	SW, SP, GW, GP	A1, A3	95%
SANDY SILTS AND CLAYS CATEGORY II	GM, SM, ML, GC, SC (WITH LESS THAN 20% PASSING #200 SIEVE)	A2, A4	95%

- NOTES:**
1. Soil removed for purpose of trench protection shall be replaced with category I or II type soils and compacted to 95% Standard Proctor in 8" to 12" lifts.
 2. Place backfill over tank and compact in 8" to 12" lifts. Do not place heavy compacting equipment directly over tank for first 24" of fill.
 3. #57 stone consolidated with mechanical plate tamp may be placed as backfill in lieu of category I or II soils. Separation fabric not required in this case.

DETAIL OF SLAB AT MANHOLE

DWG SCALE: NTS
 PLOT SCALE: 1:2
 SHEET #: 3 OF 3

SEPTTECH™ TANK H2O LOADING APPLICATION
 THE NEXT GENERATION OF ONSITE WASTEWATER PRODUCTS

FRALO PASTTECH
 One General Motors Drive
 Syracuse N.Y. 13206
 Call Toll Free 866.943.7256
 www.fralo.net