

**11
HOLE
D-BOX**

STAR™

MONSTER D-BOX

The Next Generation



Patents Pending

- 11-Hole Distribution Box, with 10 cut-away outlets
- 24" I.D. provides plenty of elbow room during installation and maintenance
- Basin can be weighted with aggregate to maintain level
- Can be brought to grade using the STAR™ Threaded Riser System
- Includes a STAR-24L threaded lid, gasket and security seal

The FRALO STAR™ Monster D-Box is the only distribution box you'll want to carry. The STAR™ system is engineered with U.V. resistant high-density polyethylene and a gasketed watertight connection.

FRALO is the proud owner and operator of the world's largest blow-mold machine. Our patented manufacturing and design process utilizes high molecular weight HDPE to produce the "**Next Generation**" of onsite wastewater products.

*FRALO looks forward to serving
all your wastewater product needs!*

FRALO
Plastech



Call Toll Free: 866.943.7256

Innovative Plastic Technology

MONSTER D-BOX

SPECIFICATIONS

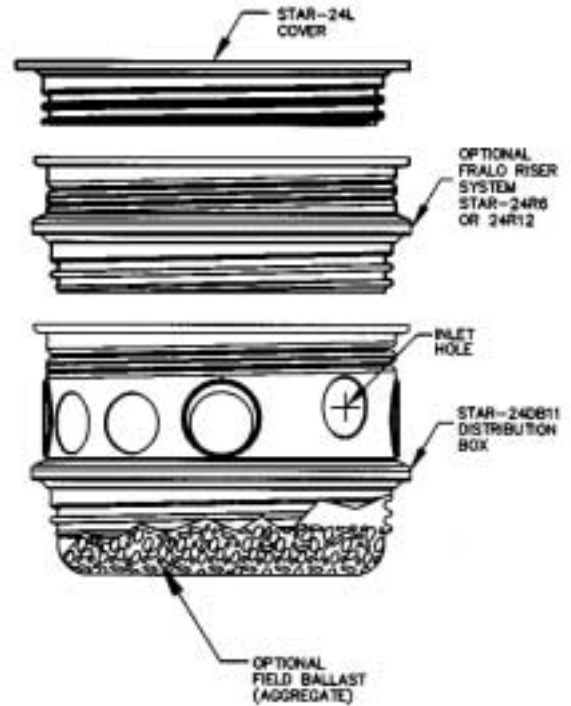
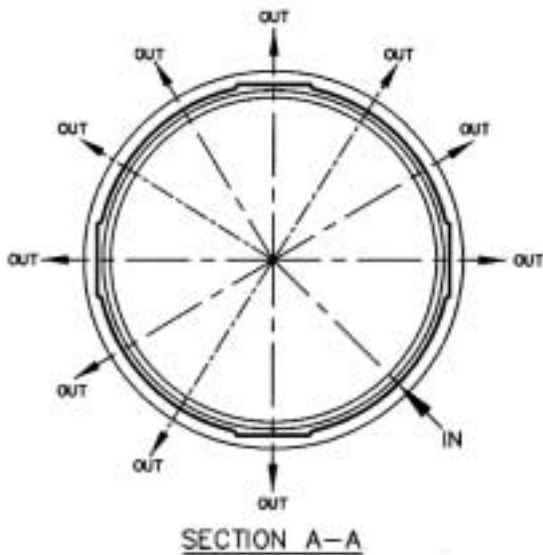
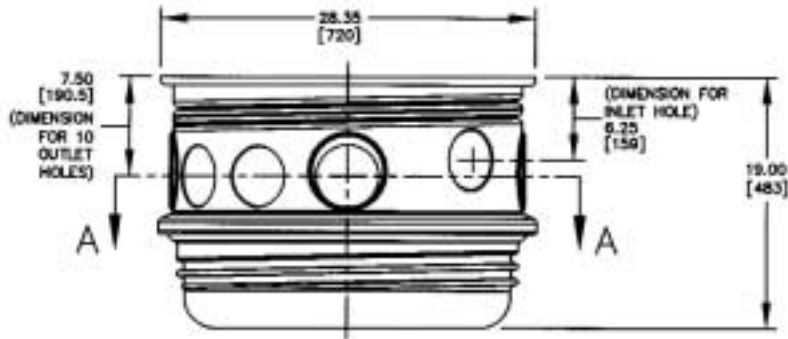

WARNING

• Use only STAR stainless steel security seals (Part # SSLOCK) to secure against unauthorized access

• Not rated for vehicular traffic loading

WARRANTY FRALO Plastech Mfg. warrants the STAR™ Monster D-Box for a period of five years from date of purchase against any manufacturing defects, providing the distribution box has been used and installed in accordance with manufacturer's written instructions. FRALO will, at its option, repair or replace any distribution box deemed to be defective and FRALO's obligations under this warranty are strictly limited to the repair and/or replacement of the defective distribution box. FRALO assumes no liability in cases of improper installation or misuse. FRALO is not responsible for any resulting contingent liabilities or charges. This warranty applies only to the original distribution box installation.

FRALO
Plastech

With an emphasis on products for the wastewater and environmental industries, FRALO Plastech is your innovative partner in business. Our products are engineered for performance over the long term. We welcome your comments and look forward to meeting your future engineered plastic product needs.

DISTRIBUTED BY:

MONSTER D-BOX

SPECIFICATIONS

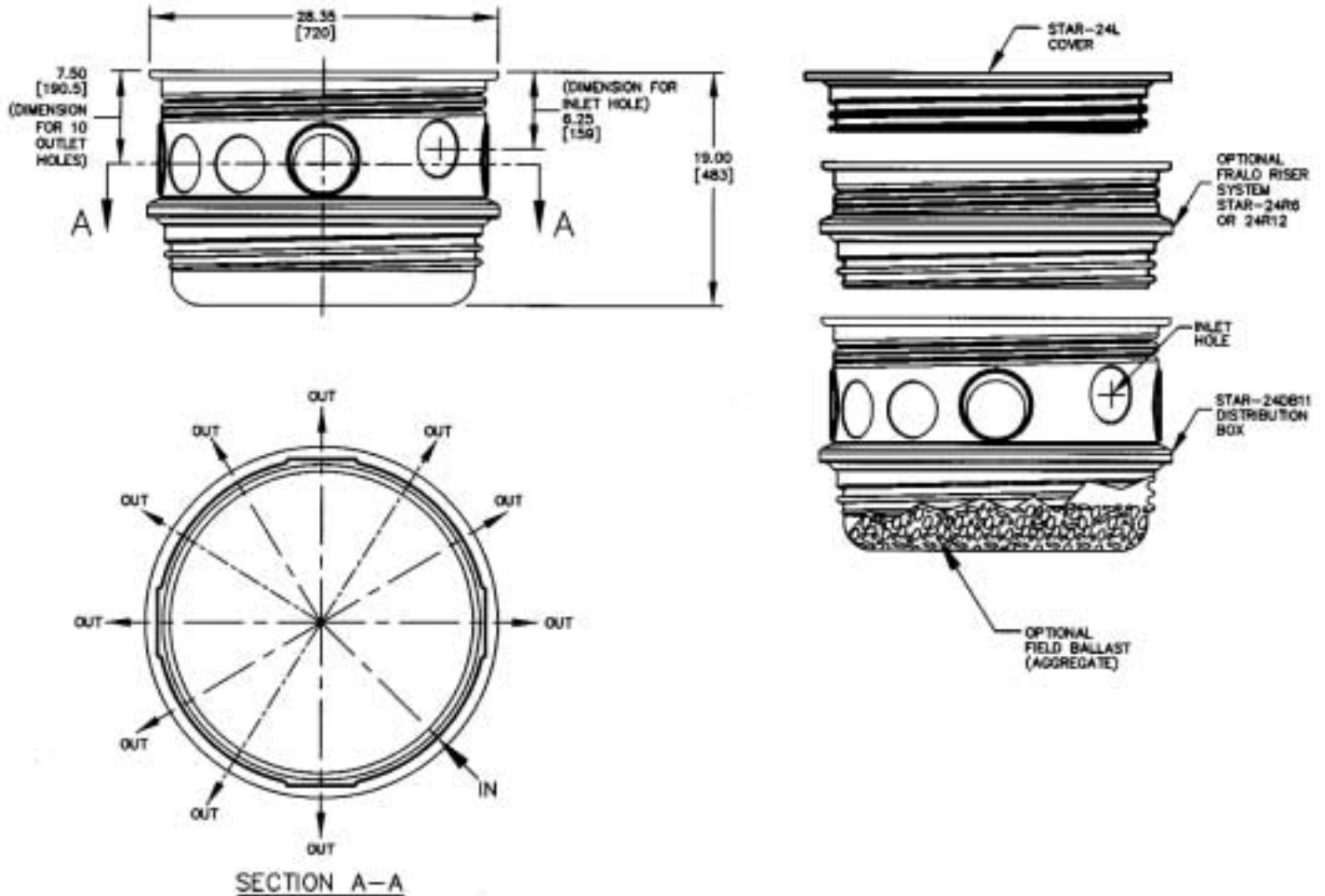

WARNING

- Use only STAR stainless steel security seals (Part # SSLOCK) to secure against unauthorized access
- Not rated for vehicular traffic loading

WARRANTY FRALO Plastech Mfg. warrants the STAR™ Monster D-Box for a period of five years from date of purchase against any manufacturing defects, providing the distribution box has been used and installed in accordance with manufacturer's written instructions. FRALO will, at its option, repair or replace any distribution box deemed to be defective and FRALO's obligations under this warranty are strictly limited to the repair and/or replacement of the defective distribution box. FRALO assumes no liability in cases of improper installation or misuse. FRALO is not responsible for any resulting contingent liabilities or charges. This warranty applies only to the original distribution box installation.

FRALO
Plastech