

HORIZONTAL STRUCTURAL REINFORCING RIBS (FULL CIRCUMFERENCE)

GAS (TOP) / LIQUID (BOTTOM) PASS-THRU SLOT INSIDE TANK

TOP

LIFTING HOLES (4 TYPICAL)

THREADED ACCESS OPENING 24" I.D. DIA. (2 TYPICAL)

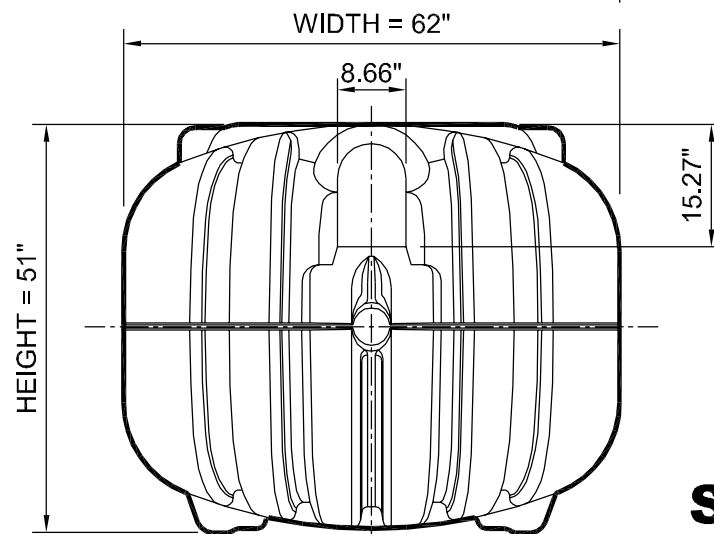
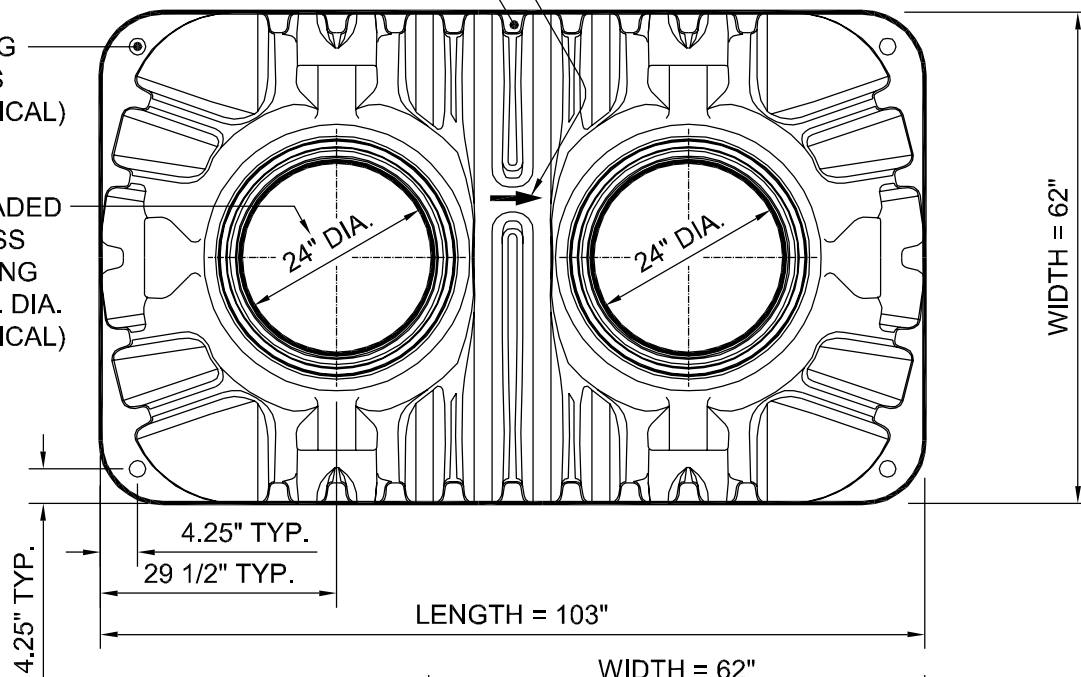

SIDE

SEPTIC TANK SPECS

DESIGN CAPACITY		TOTAL CAPACITY		WEIGHT
GALLONS	LITERS	GALLONS	LITERS	POUNDS
750	2840	1007	3812	360

SEPTTECH™ TANK
750 GALLON / MODEL ST-750
 THE NEXT GENERATION OF ONSITE WASTEWATER PRODUCTS



FRALO PLASTECH
 One General Motors Drive
 Syracuse N.Y. 13206
 Call Toll Free 866.943.7256
 www.fralo.net

DWG SCALE: 1:1

PLOT SCALE: 1:2

SHEET #:
 1 OF 3

ELEVATION

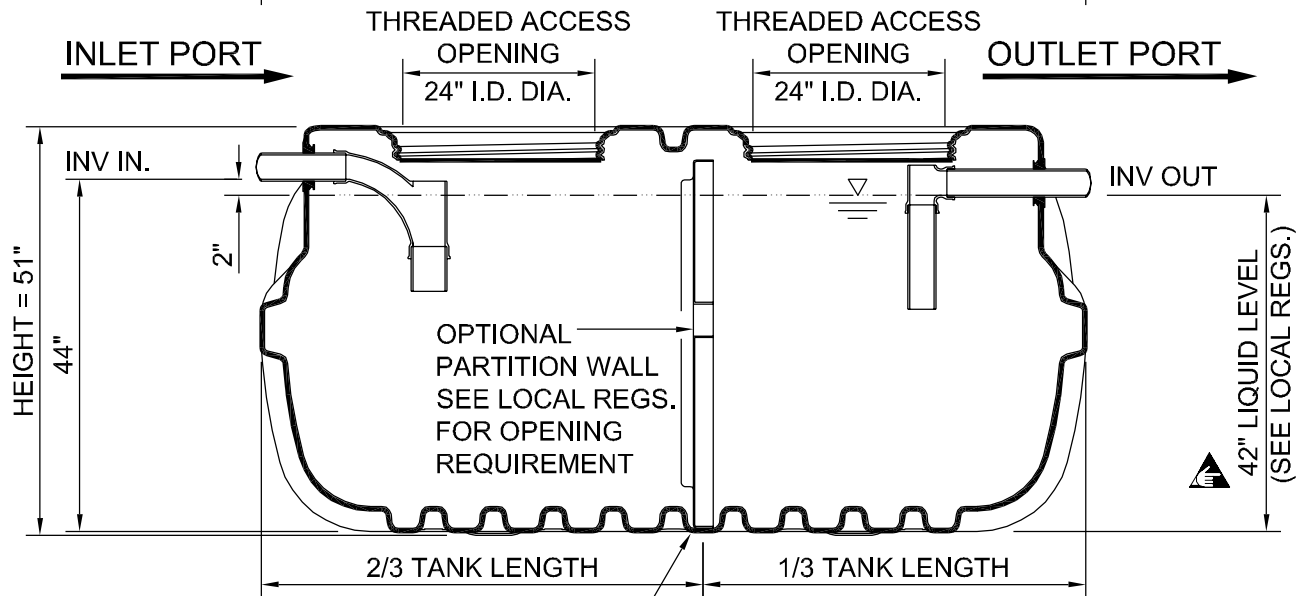
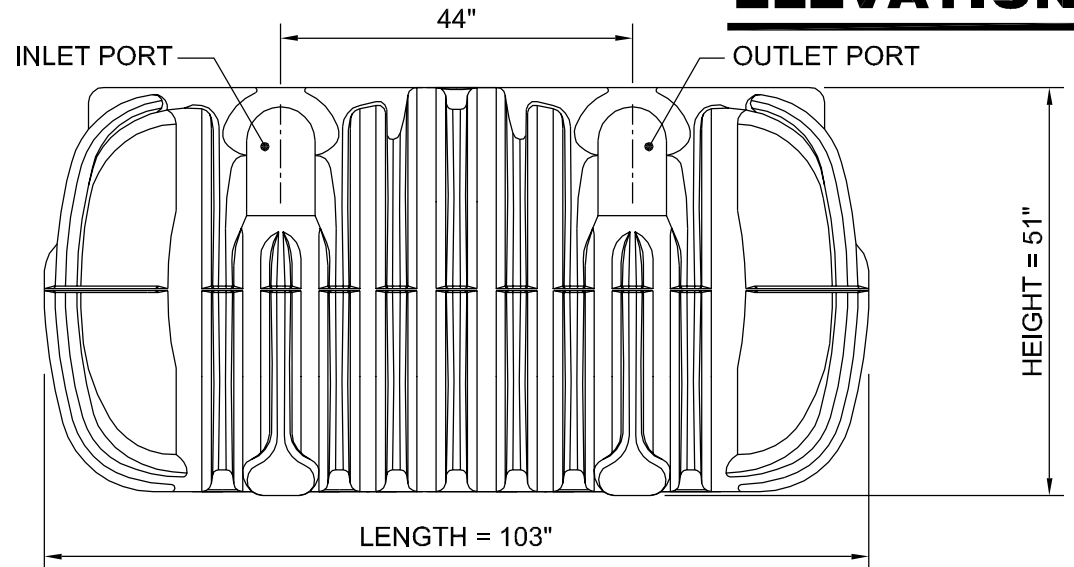

HORIZONTAL STRUCTURAL REINFORCING RIBS (FULL CIRCUMFERENCE)

SECTION

42" LIQUID LEVEL 

DWG SCALE: 1:1

PLOT SCALE: 1:2

SHEET #: 2 OF 3

SEPTTECH™ TANK
750 GALLON / MODEL ST-750
 THE NEXT GENERATION OF ONSITE WASTEWATER PRODUCTS



FRALO PLASTECH
 One General Motors Drive
 Syracuse N.Y. 13206
 Call Toll Free 866.943.7256
 www.fralo.net

ISOMETRIC

HORIZONTAL STRUCTURAL REINFORCING RIBS
(FULL CIRCUMFERENCE)

GAS (TOP) / LIQUID (BOTTOM)
PASS-THRU SLOT INSIDE TANK

THREADED ACCESS OPENING
24" I.D. DIA. (2 TYPICAL)

MULTI PORT
OUTLETS
(3 TYPICAL)

LIFTING
HOLES
(4 TYPICAL)

MULTI PORT
INLETS
(3 TYPICAL)

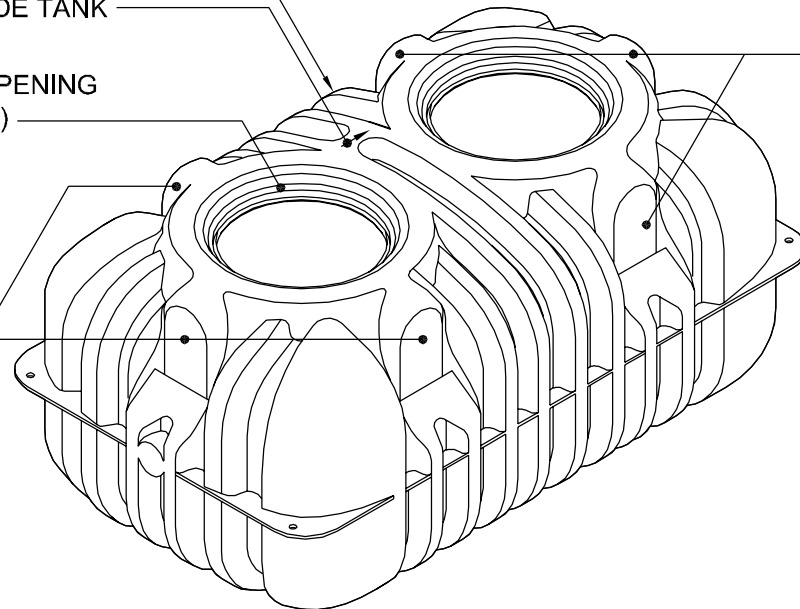

WARNING

SEPTIC TANK NOTES

1. Access at or above grade level must be secured against unauthorized access.
2. Tank is not rated for vehicular traffic loading.
3. All resin used is compliant with ASTM D 1248 as required by CSA B66 and IAPMO PS 1-2004e1.
4. Tank material of construction is HMW-HDPE.
5. Primary dimensions are in inches
6. Minimum tank wall thickness is 1/4".
7. Labeling will include: manufacturer name, liquid capacity, date, maximum burial depth, and model number.
8. Riser cover contains the following: 6" x 3" warning:
"Danger - Do not enter - Poison Gas" - written in English, French & Spanish.
9. Maximum burial depth from manufacturer is 36" unless specifically instructed otherwise by the factory.
10. Models ST-750, ST-1060, ST-1250 and ST-1500 are all certified to CSA and IAPMO standards.
11. Models ST-500, ST-900 and ST-1000E are compliant with CSA and IAPMO standards.

NOTES

DWG SCALE: 1:1

PLOT SCALE: 1:2

SHEET #:
3 OF 3

SEPTTECH™ TANK
750 GALLON / MODEL ST-750
THE NEXT GENERATION OF ONSITE WASTEWATER PRODUCTS



FRALO PLASTECH
One General Motors Drive
Syracuse N.Y. 13206
Call Toll Free 866.943.7256
www.fralo.net